

8

7

6

5

4

3

2

1

D

D

C

C

B

B

A

A

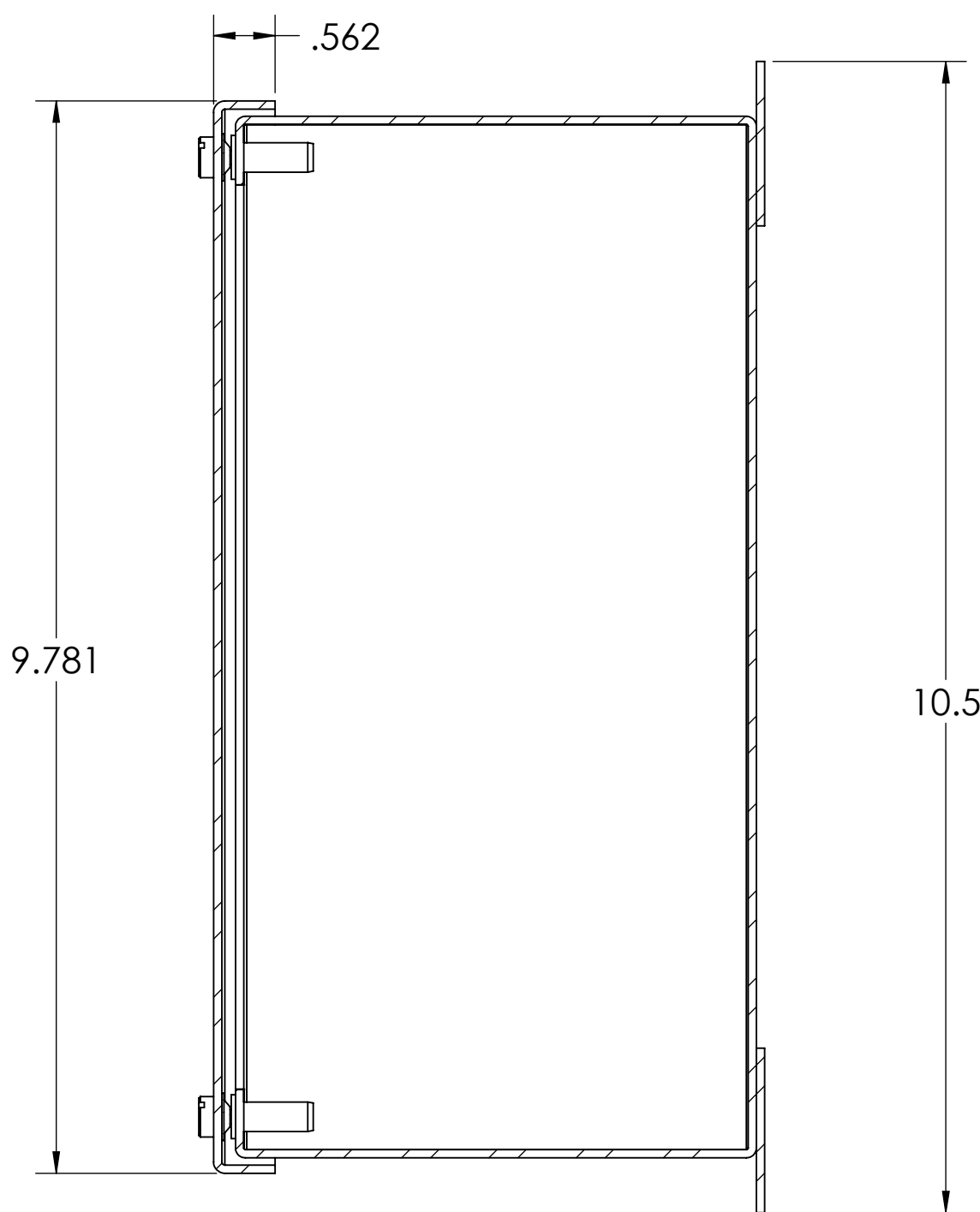
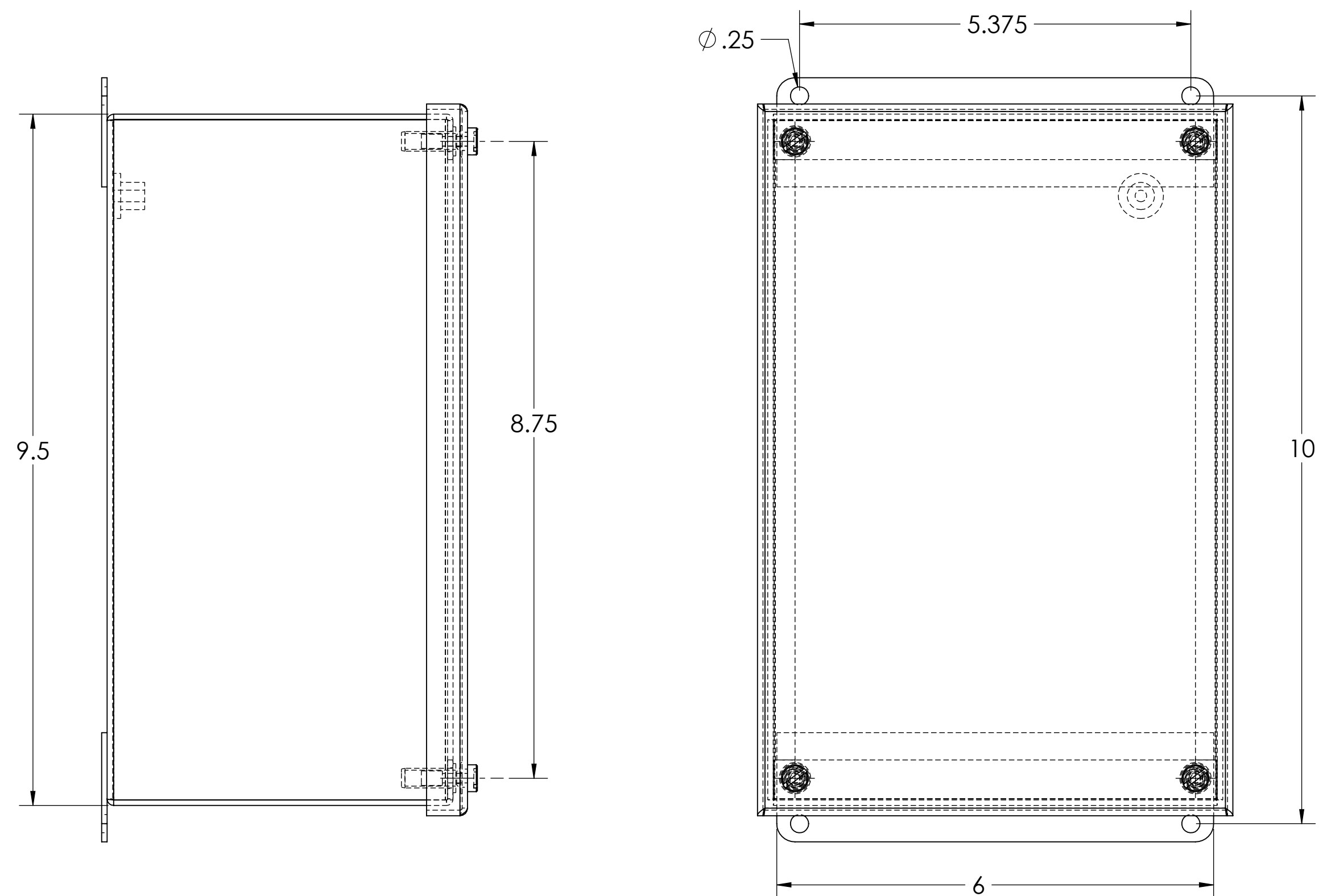
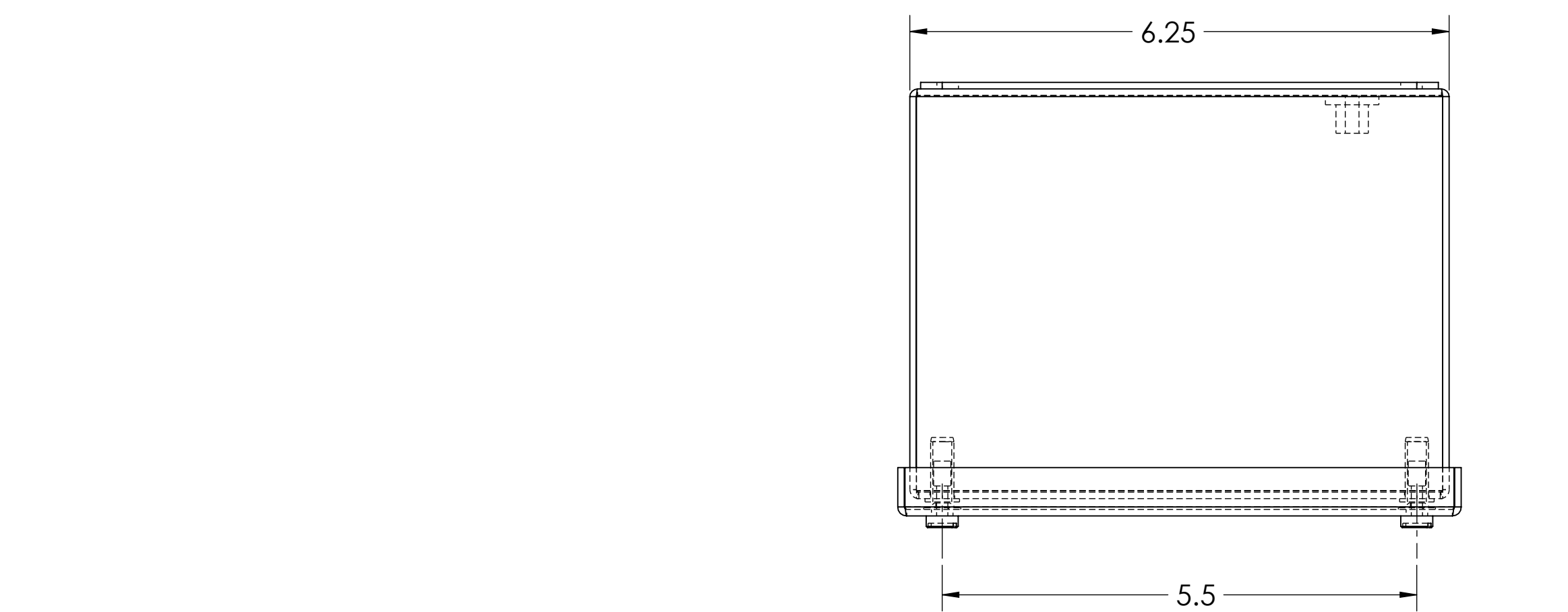

SECTION E-E  
SCALE 1 : 1.5

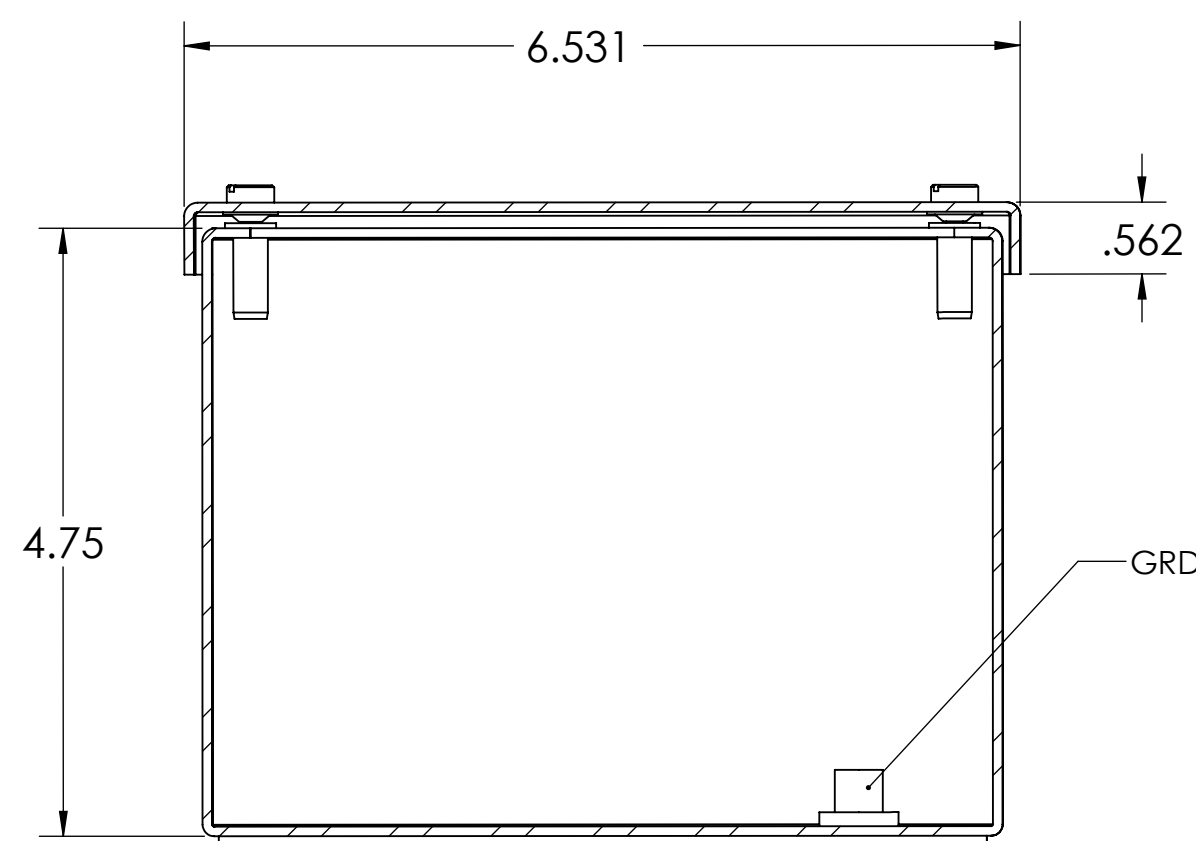

SECTION F-F  
SCALE 1 : 1.5

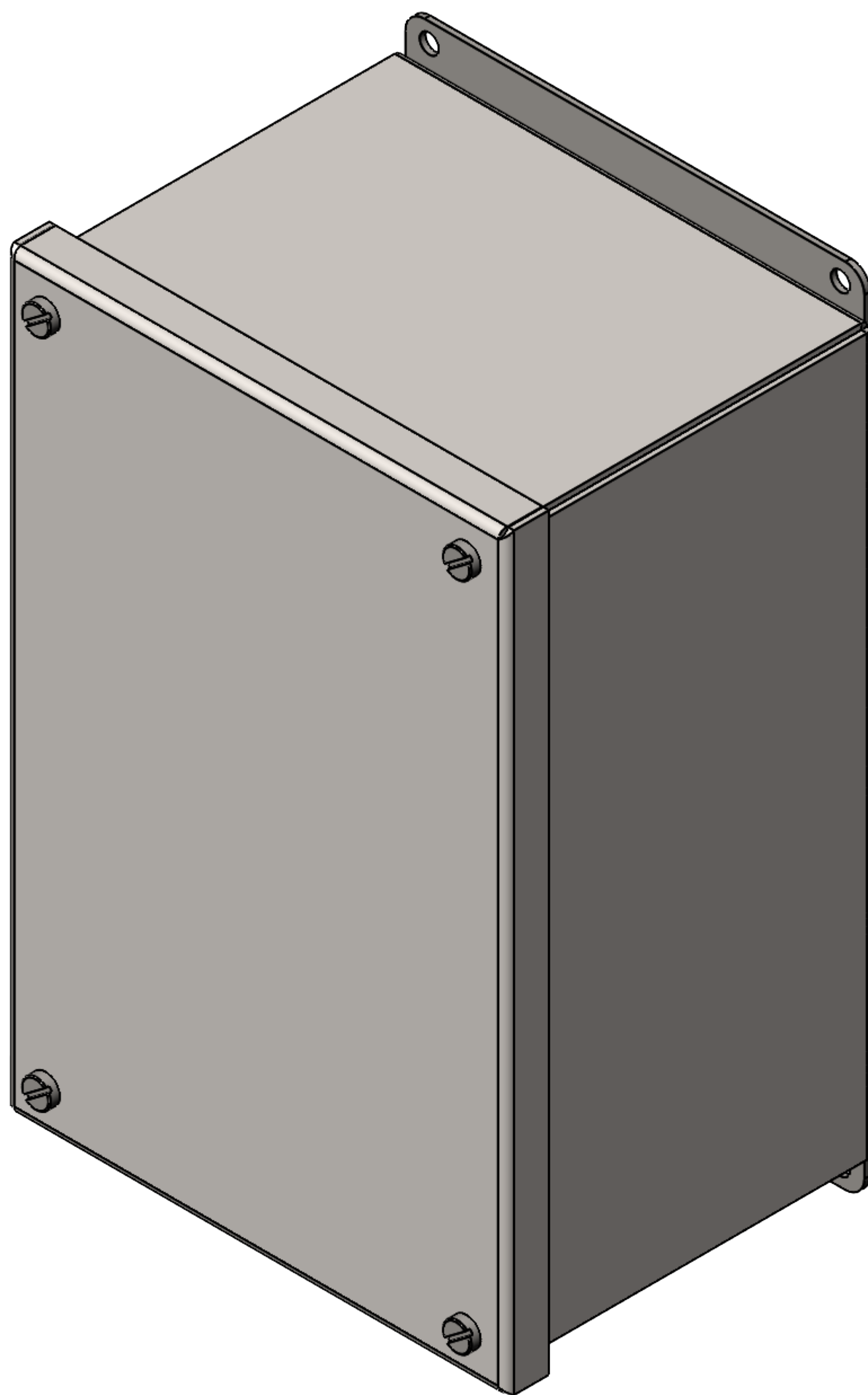

UNLESS OTHERWISE SPECIFIED:  
 DIMENSIONS ARE IN INCHES  
 TOLERANCES:  
 FRACTIONAL ±  
 ANGULAR: MACH ± BEND ±  
 TWO PLACE DECIMAL ±  
 THREE PLACE DECIMAL ±

MATERIAL:  
 FINISH:  
 DO NOT SCALE DRAWING

NAME	DATE
DRAWN BY	
ISSUED BY	

JOB ORDER NO:	
CUSTOMER DRAWING NO:	

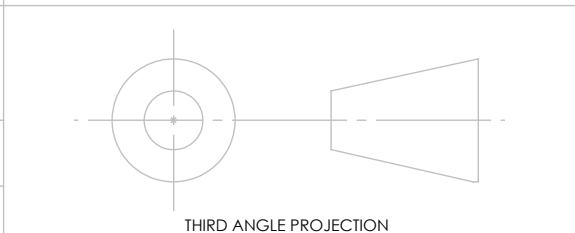

**Ralston**  
Metal Products Limited

50 Watson Road, Guelph, Ontario N1L 1E2  
 Phone: (519) 836-2968 Toll Free: 1-800-265-7611  
 Fax: (519) 836-9763 www.ralstonmetal.com

CUSTOMER:	
DWG. NO.	

SIZE	TITLE:	REV
<b>D</b>	<b>PB37-6-BC</b>	
SCALE: 1:1	WEIGHT: 6.62	SHEET 1 OF 1

**PROPRIETARY AND CONFIDENTIAL**  
 THE INFORMATION CONTAINED IN THIS DRAWING IS THE SOLE PROPERTY OF RALSTON METAL PRODUCTS. ANY REPRODUCTION IN PART OR AS A WHOLE WITHOUT THE WRITTEN PERMISSION OF RALSTON METAL PRODUCTS IS PROHIBITED.